

PRODUCT INFORMATION:

- Double section wall mount rack.
- Frame structure, max loading 60kg.
- The frame can be moved according to the requirement.
- Wall and stand installation type, optional caster and support feet for stand installing.
- Quick open side door with lock easy to install and maintain, back door can choose right or left close.
- Top and bottom wire path.
- Optional 120mm axial motor 1 piece or 2 pieces.

Material: SPCC quality cold rolled steel

Thickness: Square hole strips 1.5mm, others 1.2mm

Color: RAL9004 (Signal Black), RAL7044 (Silk Grey - on special orders)

Surface finish: degrease, acid pickling, rust prevention and parkerizing, pure water cleaning, static electricity plastic painting



Dual Section Wall Mount Cabinet

* Available in Glass door



STANDARD: Comply with ANSI/EIA RS-310-D, IEC297-2, DIN41491;
PART1, DIN41491; PART7, GB/T3047; 2-92STANDARD

SCHEMATICS:

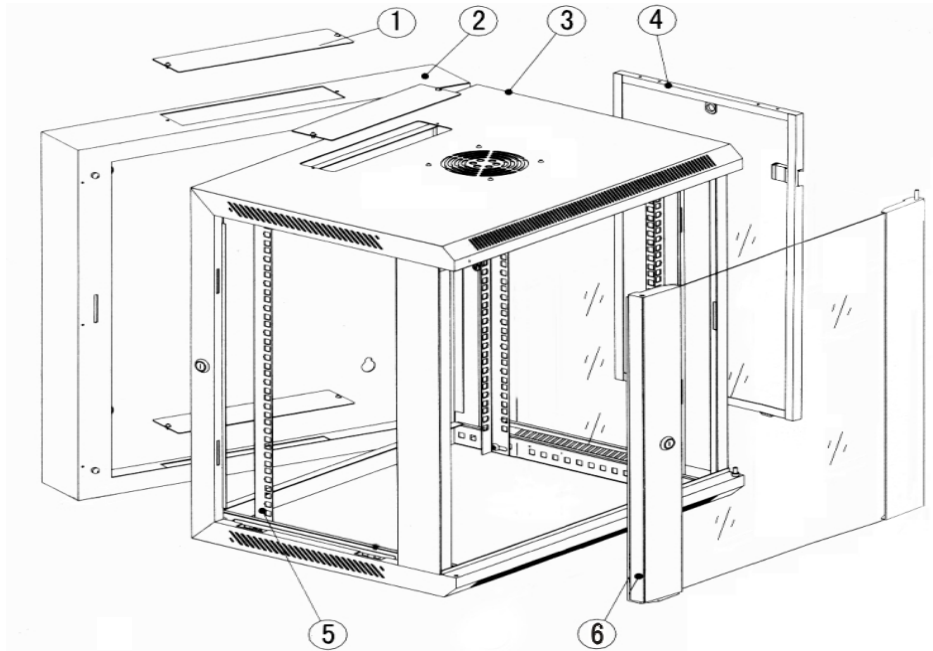

1. The Top Cover for the back section
2. The Top Cover for the front section
3. The Top
4. Side door
5. Trail
6. Front door

Product Information

Part Number	Product Description
GN-006-6512	Giganet 12U Width 600mm Depth 550mm Double Section Wall Mount Cabinet